

## TVL 0201 01 AB0 Product Engineering Specification

### 1.Scope

TVL 0201 01 AB0 is a TVS diode designed to protect one power/control line or one low speed signal line from overvoltage hazard of Electrostatic Discharge (**ESD**).

These interfaces can be used in computer interfaces protection, microprocessors protection, serial and parallel ports protection, control signal lines protection, power lines on PCB protection, latchup protection, etc. The ESD protection of TVS meets the immunity standard of IEC 61000-4-2, level 4 ( $\pm 15\text{kV}$  air,  $\pm 8\text{kV}$  contact discharge).

### 2. Explanation of Part Number

<u>TV</u>	<u>L</u>	<u>0201</u>	<u>01</u>	<u>AB0</u>
(1)	(2)	(3)	(4)	(5)

- (1) Product Type : TV=TVS Diode
- (2) Capacitance Code : L=Low Capacitance
- (3) Package Size Code
- (4) Channel Code : 01=1 Channels
- (5) Specialized Specification Code

### 3.. Circuit Diagram & Dimension

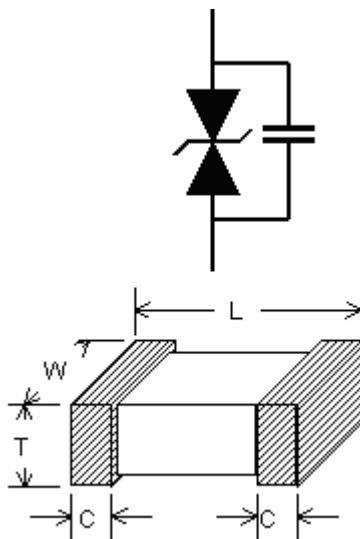

Unit: mm	0201
L	$0.60 \pm 0.05$
W	$0.30 \pm 0.05$
T	$0.30 \pm 0.05$
C	$0.20 \pm 0.1$

## 4. Specifications

### 4.1. ABSOLUTE MAXIMUM RATINGS

PARAMETER	PARAMETER	RATING	UNITS
Operating Supply Voltage	$V_{DC}$	5	V
ESD per IEC 61000-4-2 (Air)	$V_{ESD}$	$\pm 15$	kV
ESD per IEC 61000-4-2 (Contact)		$\pm 8$	
Lead Soldering Temperature	$T_{SOL}$	260 (10 sec.)	$^{\circ}C$

### 4.2. ELECTRICAL CHARACTERISTICS

ELECTRICAL CHARACTERISTICS						
PARAMETER	SYMBOL	CONDITIONS	MINI	TYP	MAX	UNIT
Reverse Stand-Off Voltage	$V_{RWM}$	$T=25^{\circ}C$ .			5	V
Reverse Leakage Current	$I_{Leak}$	$V_{RWM} = 5V, T=25^{\circ}C$ .			1	$\mu A$
Reverse Breakdown Voltage	$V_{BV}$	$I_{BV} = 1mA, T=25^{\circ}C$ .		10		V
Clamping Voltage	$V_{CL}$	$I_{PP}=1A, t_p=8/20\mu s, T=25^{\circ}C$ .		14	16	V
Channel Input Capacitance	$C_{IN}$	$V_R = 0V, f = 1MHz, T=25^{\circ}C$ .		3		pF

### 4.3. TYPICAL CHARACTERISTICS

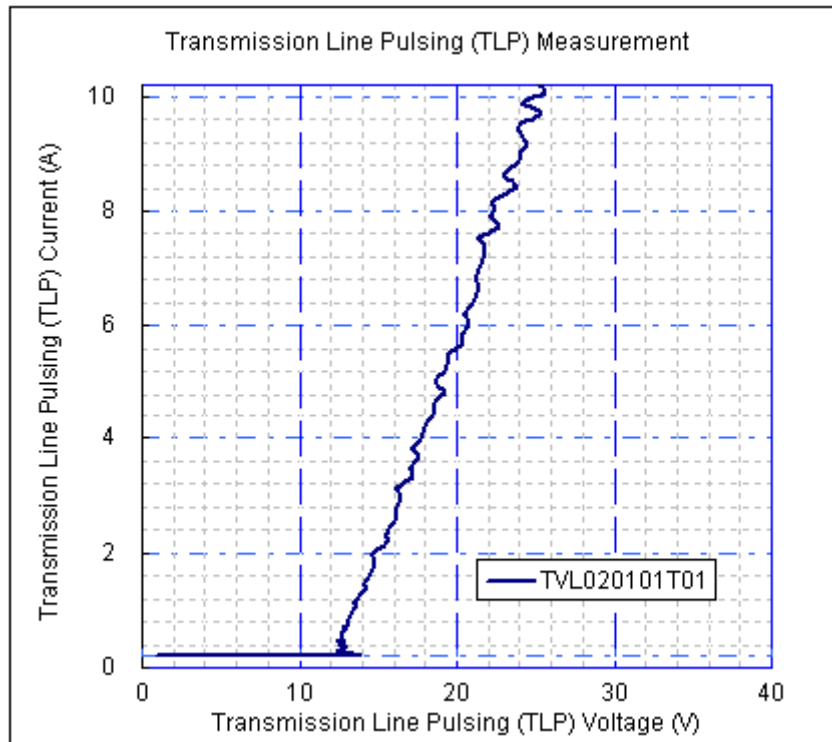

## 5. Taping Package and Label Marking

### 5.1. Carrier tape dimensions

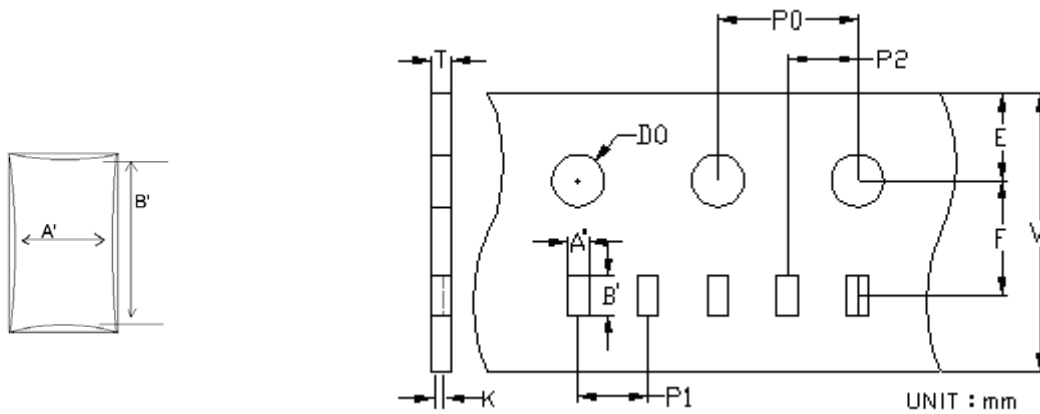

Type	A'	B'	W	E	F	P0	P1	P2	D0	T	K
0201	0.39 ±0.03	0.69 ±0.03	8.0 ±0.1	1.75 ±0.05	3.5 ±0.05	4.0 ±0.1	2.0 ±0.05	2.0 ±0.05	1.55 ±0.05	0.42 ±0.03	0.38 ±0.03

**5.2. Taping reel dimensions**

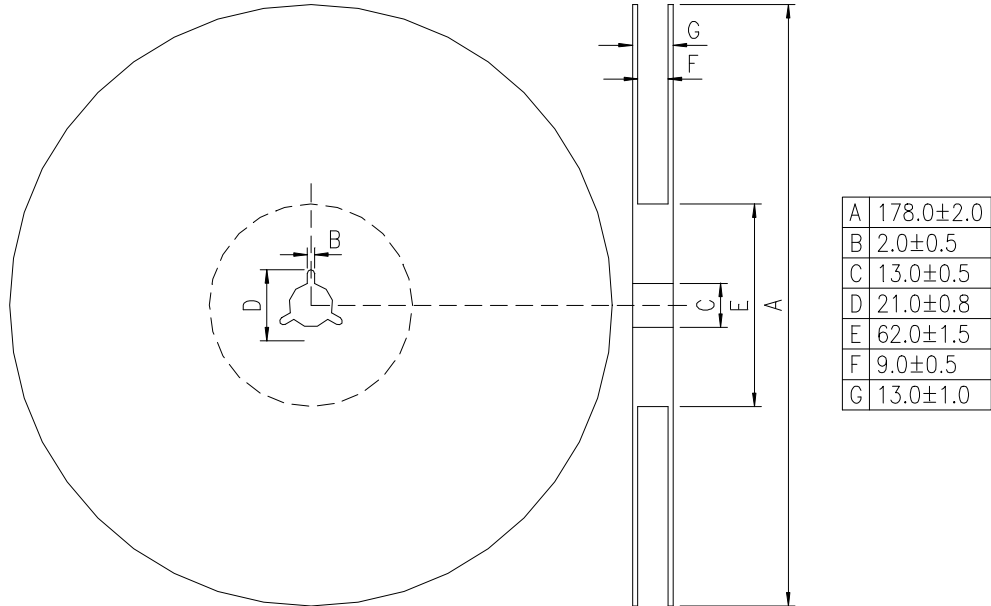

**5.4 Taping specifications**

There shall be the portion having no product in both the head and the end of taping, and there shall be the cover tape in the head of taping.

**5.5 Label Marking**

The label specified as follows shall be put on the side of reel.

- (1) Part No.
- (2) Quantity
- (3) Lot No.

\*Part No. And Quantity shall be marked on outer packaging.

**5.6 Quantity of products in the taping package**

- (1) Standard quantity : 15000pcs/Reel for TVL0201 Series
- (2) Shipping quantity is a multiple of standard quantity.

**5.6 Storage Condition with package**

Storage Time: 12 months max  
 Storage Temperature : 5 to 30°C  
 Relative Humidity: 0 to 60 %

## 6. Precautions for Handling

### 6.1. Solder cream in reflow soldering

Refer to the recommendable land pattern as printing mask pattern for solder cream.

- (1) Print solder in a thickness of 150 to 200  $\mu\text{m}$ .
- (2) Dimensions: millimeters (inches)

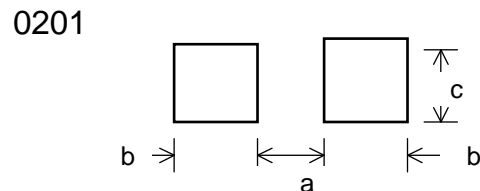

Unit: mm

Type	a	b	c
0201	0.2~0.3	0.25~0.30	0.3~0.4

**Notes: This LAND LAYOUT is for reference purposes only. Please consult your manufacturing partners to ensure your company's PCB design guidelines are met.**

### 6.2. Precaution for handling of substrate

Do not exceed to bend the board after soldering this product extremely.

(Reference examples)

- Mounting place must be as far as possible from the position, which is close to the break line of board, or on the line of large holes of board.
- Do not bend extremely the board, in mounting another components.  
If necessary, use back-up pin (support pin) to prevent from bending extremely.
- Do not break the board by hand. We recommend using the machine or the jig to break it.

### 6.3. Precaution for handling of substrate

Do not exceed to bend the board after soldering this product extremely.

(Reference examples)

- Mounting place must be as far as possible from the position, which is close to the break line of board, or on the line of large holes of board.
- Do not bend extremely the board, in mounting another components.  
If necessary, use back-up pin (support pin) to prevent from bending extremely.
- Do not break the board by hand. We recommend using the machine or the jig to break it.

**6.4. Precaution for soldering**

Note that rapid heating, rapid cooling or local heating will easily damage this product. Do not give heat shock over 100°C in the process of soldering. We recommend taking preheating and gradual cooling.

**6.5. Recommendable reflow soldering**

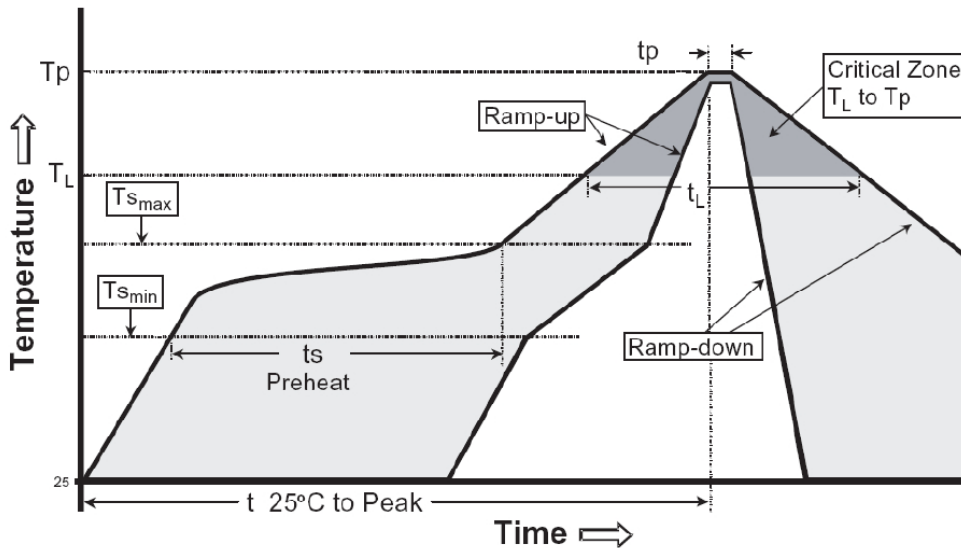

Profile Feature	Pb free Assembly
Average Ramp Rate (Ts max to Tp)	3 °C/second max
Preheat	
- Temperature Min (Ts <sub>min</sub> )	150°C
- Temperature Min (Ts <sub>max</sub> )	200°C
- Time(ts <sub>min</sub> to ts <sub>min</sub> )	60-180 seconds
Time maintained above:	
- Temperature (T <sub>L</sub> )	217°C
- Time (t <sub>L</sub> )	60-150 seconds
Peak Temperature (T <sub>p</sub> )	260°C +0/-5 °C
Time within 5 °C of actual Peak Temperature (T <sub>p</sub> )	20-40 seconds
Ramp-Down Rate	6 °C/second max.
Time 25°C to Peak Temperature	8 minutes max

\*According to J-STD-020C

## 6.6. Soldering gun procedure

Note the follows, in case of using solder gun for replacement.

- (1) The tip temperature must be less than 350°C for the period within 5 seconds by using soldering gun less than 30 W.
- (2) The soldering gun tip shall not touch this product directly.

## 6.7. Soldering volume

Note that excess of soldering volume will easily get crack the body of this product.